

KEEP FOR FUTURE REFERENCE

OPERATING INSTRUCTIONS



908 W. Main • P.O. Box 368
Laurel, MT USA 59044
800-548-7341 (phone)
406-628-8231 (phone)
406-628-8354 (fax)
www.WPG.com

 **INTENDED FOR USE BY SKILLED
PROFESSIONALS • READ AND
UNDERSTAND BEFORE OPERATING**



MANUAL ROTATOR/TILTER, DC-VOLTAGE

Model numbers: MRT411LDC (shown), MRT49DC,
MRT4HV11DC

Record serial number in blank space above (to locate, see serial label on the product).







TABLE OF CONTENTS

SPECIFICATIONS	3
SAFETY	5
OPERATING FEATURES	6
ASSEMBLY	7
TO CHANGE THE PAD FRAME CONFIGURATION	9
Installing/Removing Extension Arms and Repositioning Vacuum Pads	10
Using Secondary Rotation Stops	11
INTENDED USE	12
LOAD CHARACTERISTICS.....	12
OPERATING ENVIRONMENT	13
DISPOSAL OF THE LIFTER	13
OPERATION	14
BEFORE USING THE LIFTER	14
Taking Safety Precautions	14
Performing Inspections and Tests	14
Checking the Battery.....	15
TO ATTACH THE PADS TO A LOAD	16
Positioning the Lifter on the Load.....	16
Sealing the Pads on the Load	17
Reading the Vacuum Gauge.....	17
TO LIFT AND MOVE THE LOAD	18
Interpreting the Warning Light and Optional Warning Buzzer	18
Watching Vacuum Indicators	18
Controlling the Lifter and Load	19
In Case of a Power Failure.....	19
TO ROTATE THE LOAD	20
TO TILT THE LOAD	21
TO RELEASE THE PADS FROM THE LOAD	23
AFTER USING THE LIFTER	23
Storing the Lifter	23
INSPECTIONS AND TESTS	25
INSPECTION SCHEDULE	25

TABLE OF CONTENTS

TESTING	26
Lifter/Load Compatibility Test.....	26
Operational Tests	27
Vacuum Test.....	27
Rated Load Test.....	28
MAINTENANCE	29
VACUUM PAD MAINTENANCE.....	29
Pad-to-Load Friction Coefficient	29
Pad Inspection	29
Pad Cleaning	30
BATTERY RECHARGE.....	31
REPLACEMENT PARTS.....	32
LIMITED WARRANTY	33
TO OBTAIN REPAIRS OR WARRANTY SERVICE.....	33

SPECIFICATIONS

Product Description	Designed for use with hoisting equipment, MRT4-DC lifters support loads using vacuum and manipulate loads using manual 360° rotation and manual 90° tilt motions.		
Model Number	MRT49DC	MRT4HV11DC	MRT411LDC
Vacuum Pads¹ (4 each, standard rubber)	9" [23 cm] nom. diameter (Model VPFS9)	10" [25 cm] nom. diameter, lipped (Model HV11)	11" [28 cm] nom. diameter, lipped (Model G3370)
Pad Spread²	----- (to outer edges) -----		
Length – Maximum	75¼" [192 cm]	77¼" [197 cm]	78¼" [199 cm]
Length – Minimum	29¾" [76 cm]	31¾" [81 cm]	32¾" [83 cm]
Width – Maximum	46½" [119 cm]	48½" [124 cm]	49½" [126 cm]
Width – Minimum	12¾" [33 cm]	14¾" [38 cm]	15¾" [40 cm]
 Maximum Load Capacity³			
Per-Pad	125 lbs [56.5 kg]	150 lbs [68 kg]	175 lbs [80 kg]
Total	500 lbs [225 kg]	600 lbs [270 kg]	700 lbs [320 kg]
 Lifter Weight	135 lbs [62 kg]		
Power System	12 volts DC, 3.5 amps		
Battery Capacity	7 amp-hours		
 Rotation Capability	Manual, 360°, with latching at each ¼ turn (when required)		
 Tilt Capability	Manual, 90°, with automatic locking in vertical position		
Product Options	See separate instructions about options.		
 Operating Elevation	Up to 6,000' [1,828 m]		
 Operating Temperatures	32° — 104° F [0° — 40° C]		
Service Life	20,000 lifting cycles, when used and maintained as intended ⁴		
ASME Standard BTH-1	Design Category "B", Service Class "O" (see www.WPG.com for more information)		

- 1..... Available with other rubber compounds for special purposes (see www.WPG.com).
- 2..... The illustrations under "TO CHANGE THE PAD FRAME CONFIGURATION" on page 9 show the Pad Spread for all approved pad frame configurations.
- 3..... The Maximum Load Capacity is rated at a vacuum of 16" Hg [-54 kPa] on clean, smooth, nonporous flat surfaces with a friction coefficient of 1. Pad compound, load rigidity, strength, surface conditions, overhang, angle, center of gravity and temperature can also affect the lifting capacity. A "qualified person" should evaluate the effective lifting capacity for each use (see definition under "Rated Load Test" on page 28).
- 4..... Vacuum pads, filter elements and other wear-out items are excluded.

!!–CE–!! This symbol appears only when a CE Standard is different from other applicable standards. CE requirements are mandatory in the European Union, but may be optional elsewhere.

SPECIFICATIONS

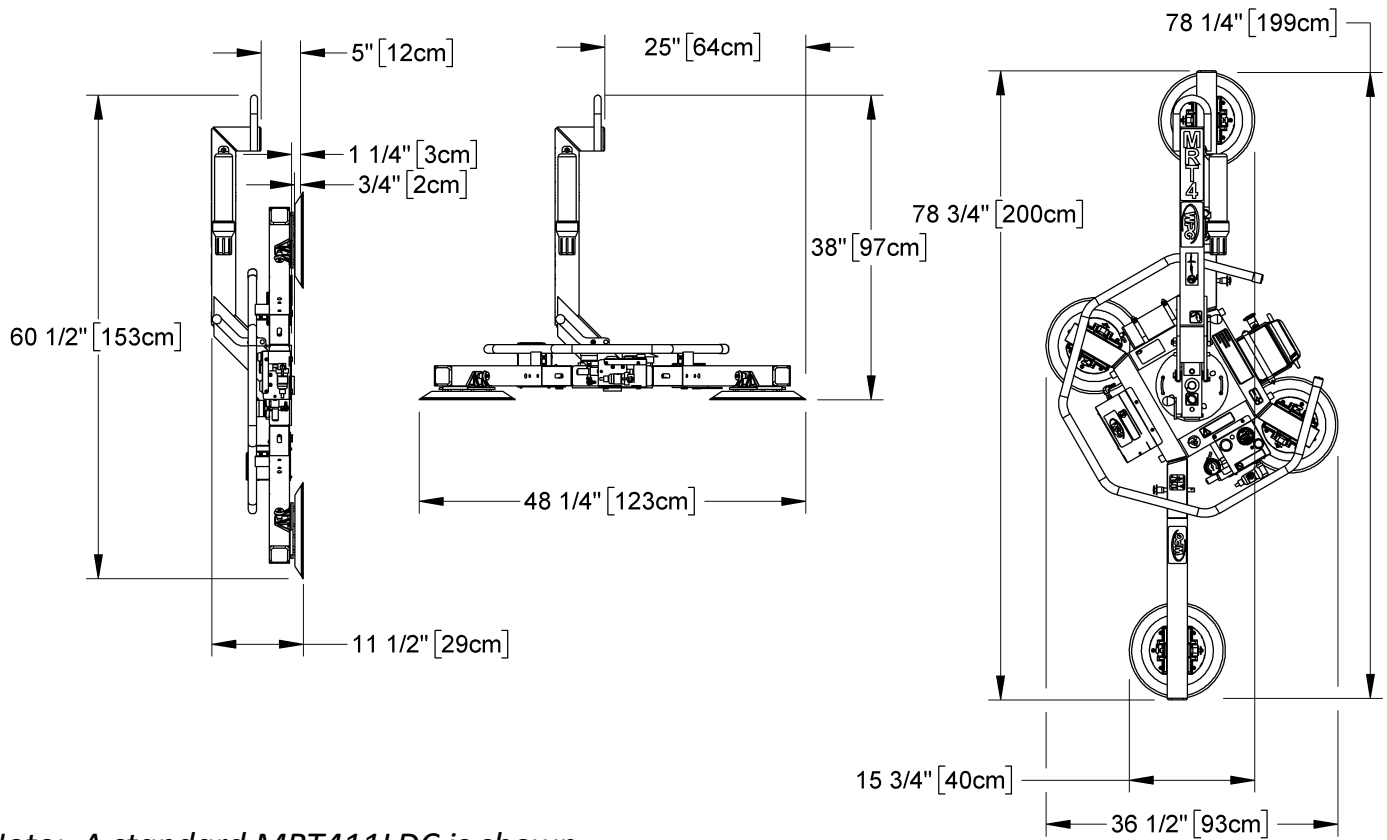
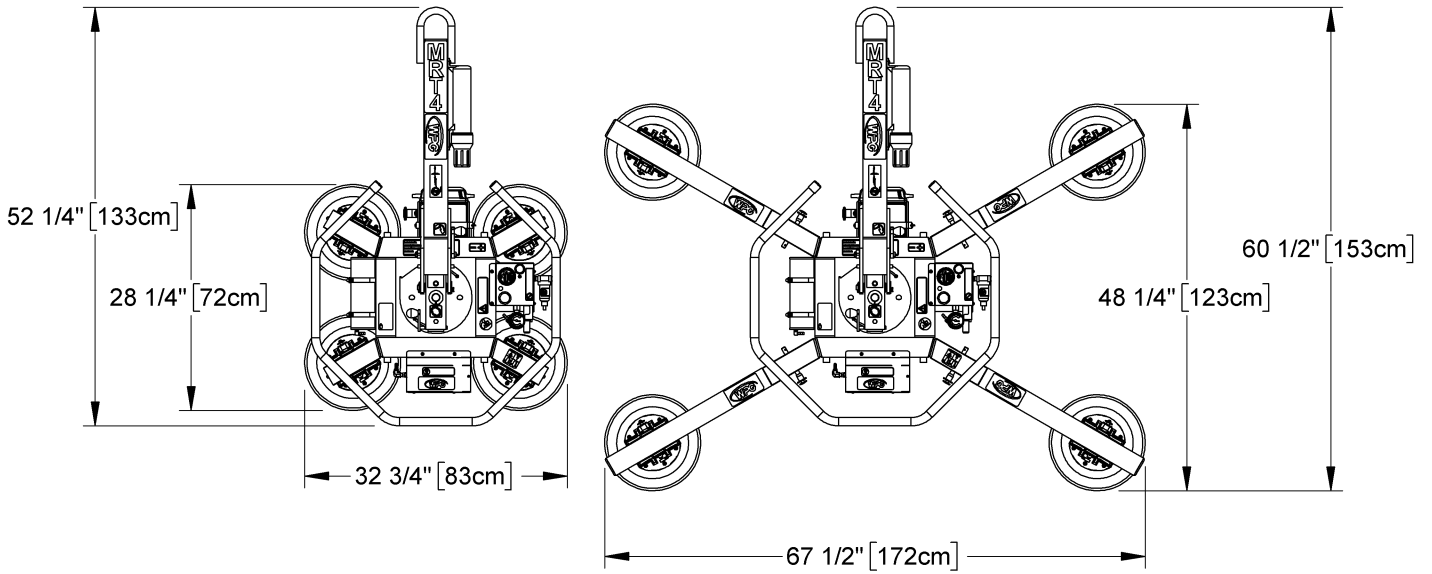

Note: A standard MRT411LDC is shown.

SAFETY



Wear personal protective equipment that is appropriate for the load material. Follow trade association guidelines.



Do not remove or obscure safety labels.



Do not make any modifications to the lifter (see "LIMITED WARRANTY").



Use the lifter only in an approved "OPERATING ENVIRONMENT" (see "INTENDED USE").



Do not use a lifter that is damaged, malfunctioning, or missing parts.



Do not use a lifter if the sealing edge of any vacuum pad is cut or otherwise damaged.



Do not use a lifter to lift cracked or broken glass.



Do not exceed the Maximum Load Capacity or lift loads the lifter is not designed for (see "INTENDED USE").



Do not use a lifter if the Maximum Load Capacity or any safety label appears to be missing or obscured.



Make sure the contact surfaces of the load and vacuum pads are clean before attaching the lifter (see "MAINTENANCE").



Position the vacuum pads correctly on the load before lifting (see "OPERATION: Positioning the Lifter on the Load").



Do not lift a load if any vacuum indicator shows inadequate vacuum.



Keep unauthorized personnel away from the lifter, to avoid injury in case of an unintended load release.



Do not touch the vacuum release controls during a lift.



Do not allow people to ride on the lifter or the load.



Do not lift a load higher than necessary or leave suspended loads unattended.



Do not position a loaded or unloaded lifter over people.



Before servicing a powered lifter, place the power control in the inactive position and, when possible, disconnect the power source.

OPERATING FEATURES

Features shown here are underlined> on their first appearance in each section following.

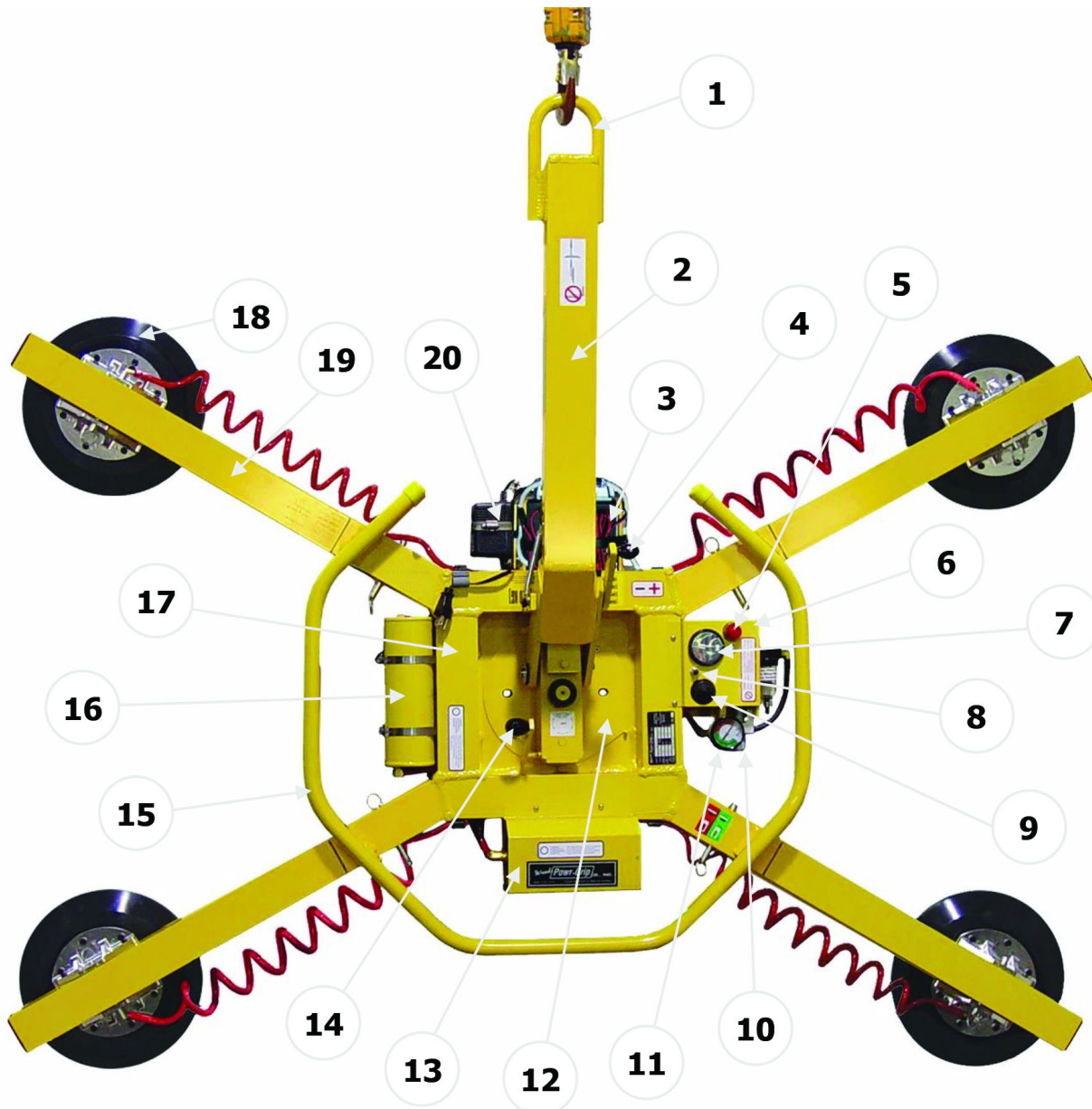

- | | | | | | |
|---|------------------------------|----|--------------------------------------|----|---------------------|
| 1 | LIFT POINT | 8 | BATTERY TEST BUTTON | 15 | CONTROL HANDLE |
| 2 | LIFT BAR | 9 | LOW VACUUM WARNING BUZZER (optional) | 16 | VACUUM RESERVE TANK |
| 3 | BATTERY | 10 | VALVE HANDLE | 17 | PAD FRAME |
| 4 | TILT RELEASE LEVER | 11 | VACUUM GAUGE | 18 | VACUUM PAD |
| 5 | LOW VACUUM WARNING LIGHT | 12 | ROTATION WEAR PLATE | 19 | EXTENSION ARM |
| 6 | Enclosure with VACUUM SWITCH | 13 | Cover for VACUUM PUMP | 20 | BATTERY CHARGER |
| 7 | BATTERY GAUGE | 14 | ROTATION RELEASE LEVER | | |
- Not shown: INSTRUCTIONS CANISTER

Note: The lifter model MRT411LDC is shown here. Although some of the following photos do not show this specific lifter, they all illustrate how this kind of lifter functions.

ASSEMBLY



- 1) Remove all lifter restraints and save them with the shipping container for future use.
- 2) Suspend the lifter from appropriate hoisting equipment:

2.1) Select a crane and/or hoist rated for the Maximum Load Capacity plus the Lifter Weight.

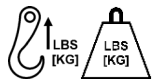

Note: Any lifter use must comply with all statutory or regulatory standards for hoisting equipment in your region.

2.2) Disengage any tilt locks or latches, and raise the lift bar (figs. 2A-C).

2.3) Attach the hoisting hook to the lift point (figs. 2D-E). Use rigging (fig. 2F) as needed to make sure the hook does not interfere with the load.



Only use rigging rated for Maximum Load Capacity plus Lifter Weight.



Make sure hook has restraining latch (circled).



ASSEMBLY

2.4) Use the hoisting equipment to remove the lifter from the shipping container. Avoid damaging the vacuum pads.



3) Connect the electrical connectors (figs. 3A-B and figs. 3C-D).

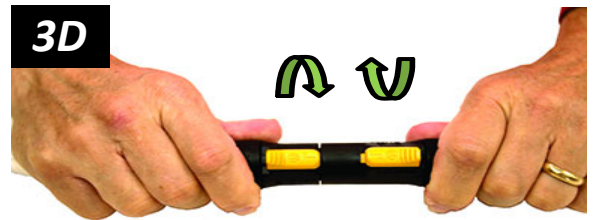
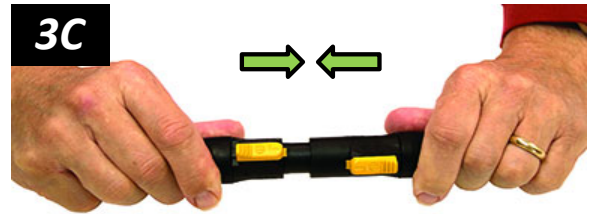

4) Assemble the pad frame for optimal load support (see “TO CHANGE THE PAD FRAME CONFIGURATION” on page 9). Remove the pad covers (fig. 4A) and save them for future use.

5) Perform tests as required under “TESTING” on page 26).



ASSEMBLY

TO CHANGE THE PAD FRAME CONFIGURATION

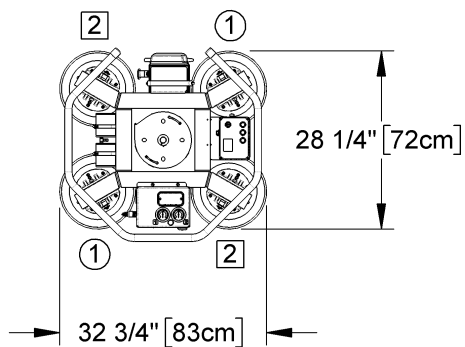
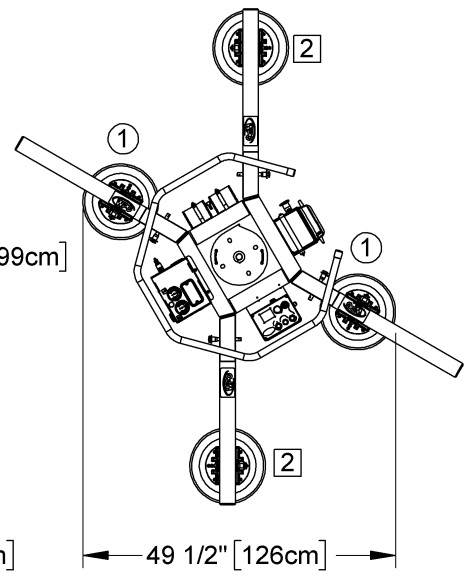
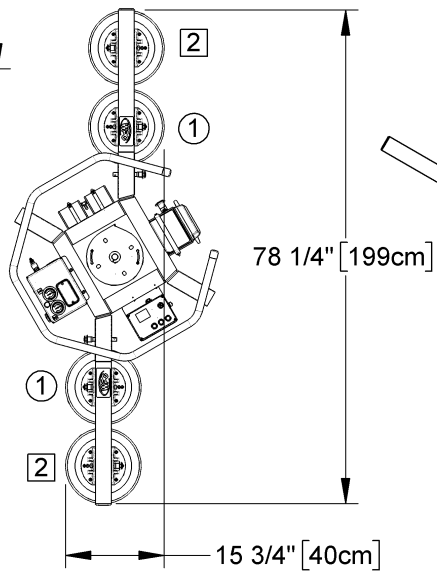
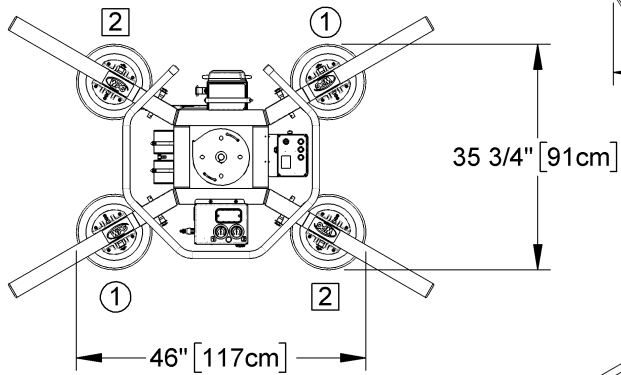
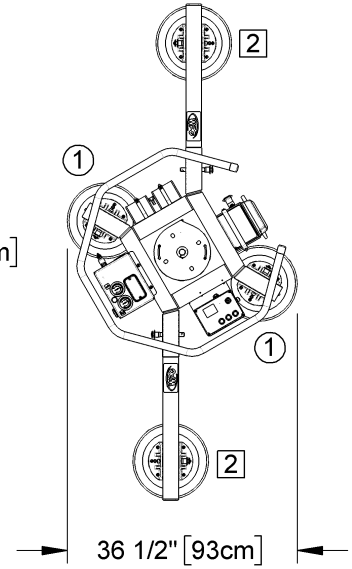
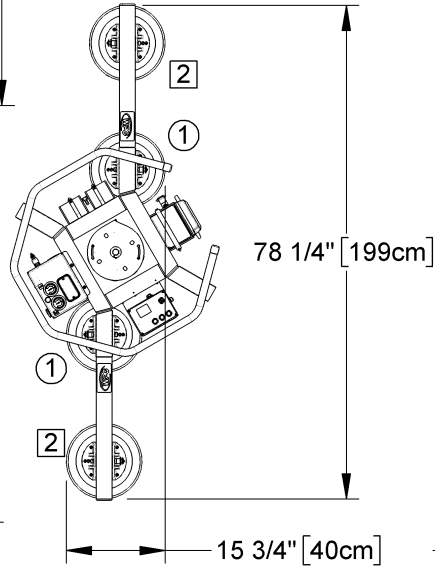
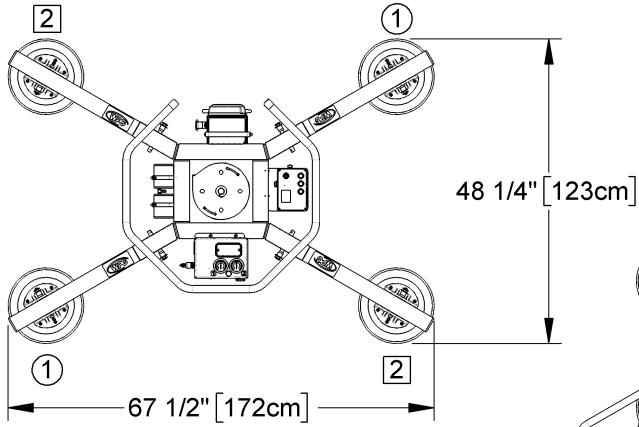

ASSEMBLY

Various pad frame configurations enable the lifter to match different load dimensions. The illustrations on the preceding page show all approved configurations. Dimensions show Pad Spread for a standard MRT411LDC(3) lifter (see “SPECIFICATIONS” on page 3 for other models).

Caution: If the lifter is equipped with a dual vacuum system, position the vacuum pads for the 2 circuits (marked “1” and “2” in the preceding illustrations).

- 1) Choose an approved configuration to maximize support across the load surface and to minimize load overhang (see “LOAD CHARACTERISTICS” on page 12).



Use only approved pad frame configurations.



Securely position vacuum hoses to avoid damage during lifter operation.

- 2) Install or remove the extension arms and reposition the movable pad mounts as needed.

Installing/Removing Extension Arms and Repositioning Vacuum Pads

- 1) Remove the cotterless hitch pin (circled in fig. 1A) that secures the movable pad mount to the pad frame.
- 2) Remove the vacuum pad from the pad frame (fig. 2A).
- 3) Insert the extension arm into the pad frame (fig. 3A). Then insert a cotterless hitch pin to secure it (fig. 3B).
- 4) Position the movable pad mount on the extension arm (fig. 4A). Then insert a cotterless hitch pin to secure it (fig. 4B).

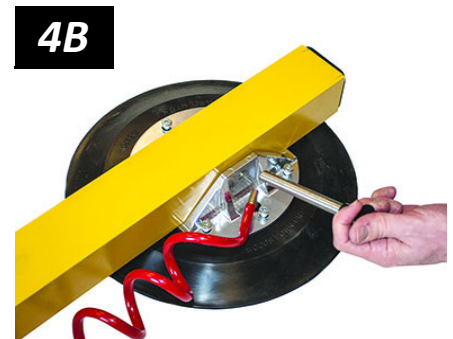

Notes: Repeat or reverse these steps to configure the pad frame as needed. Store removed components in a clean, dry location.

ASSEMBLY

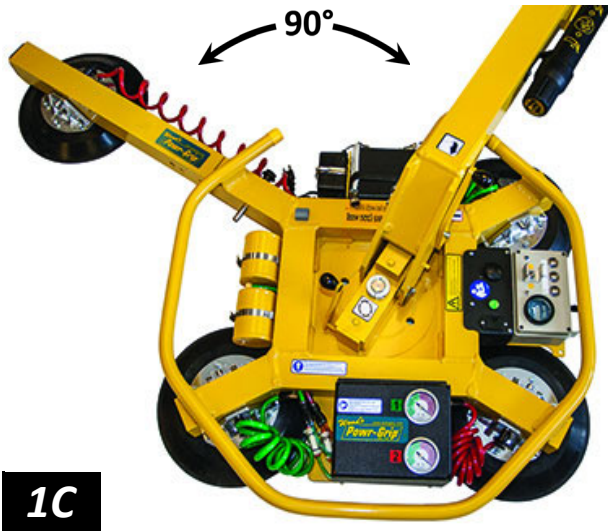
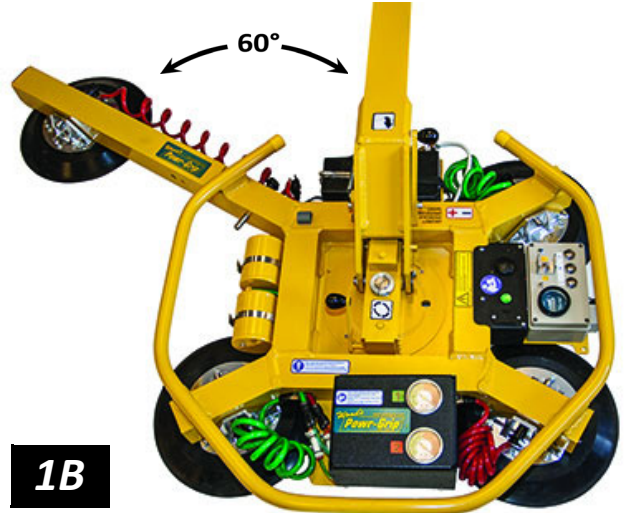

Using Secondary Rotation Stops

Align the secondary rotation stops for correct use of the pad frame in long, narrow configurations:

- 1) Loosen the 2 screws that secure the rotation wear plate (fig. 1A).
- 2) Rotate the wear plate to align with the secondary rotation stops (figs. 1B-C).
- 3) Tighten the screws securely (circled in fig. 1D).

Note: Reverse these steps to realign the primary rotation stops.

LOAD CHARACTERISTICS

Make sure the vacuum lifter is intended to handle each load according to these requirements:



Do NOT lift explosives, radioactive substances or other hazardous materials.



- The load weight must not exceed the Maximum Load Capacity.
- The load must be a single piece of relatively nonporous material with a flat and relatively smooth contact surface.^{1, 2} To determine whether the load is too porous or rough, perform a “Lifter/Load Compatibility Test” on page 26.
- The load's contact surface must be able to obtain a friction coefficient of 1 with the lifter's vacuum pads (see “Pad-to-Load Friction Coefficient” on page 29). Otherwise, the capacity should be derated appropriately.
- The load's surface temperature must not exceed the Operating Temperatures.³
- The load's *minimum* length and width are determined by the current Pad Spread (see “SPECIFICATIONS” on page 3).
- The load's *maximum* length and width are determined by its allowable overhang.⁴
- 1" [2.5 cm] is the allowable thickness at Maximum Load Capacity.⁵

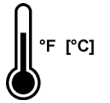

Note: Standard vacuum pads can stain or deform load surfaces with light colors or soft coatings. Test such surfaces for damaging effects before using the lifter on them.⁶

1..... Although concave vacuum pads can also attach to some curved loads, curvature can reduce lifting capacity. Contact WPG for more information.

2..... A “single piece” of material includes curtainwall assemblies, unitized glazing systems and similar construction units.

3..... Vacuum pads made from a heat-resistant rubber compound can enable you to lift loads with higher surface temperatures. Contact WPG or an authorized dealer for more information.

4..... The allowable overhang is the amount of load material that can extend sideways beyond the vacuum pad without breaking or otherwise being damaged. This depends on the load material, its thickness, and the angle of handling (if any). Since every material has different physical properties, the allowable overhang must be evaluated separately for each load type. Contact WPG or an authorized dealer for more information.

5..... However, the allowable thickness increases as load weight decreases. Contact WPG for more information.

6..... Alternative rubber compounds are available for these purposes. Contact WPG or an authorized dealer for more information.

INTENDED USE

OPERATING ENVIRONMENT

Make sure the vacuum lifter is intended for use in each work environment, given the following restrictions:

- This lifter is not intended for any environment that is dangerous to the operator or damaging to the lifter. Avoid environments containing explosives, caustic chemicals and other dangerous substances.



Never use lifter in dangerous environments.



Metal particles and similar environmental contaminants could result in vacuum pump failure.

- The work environment is limited by the Operating Elevation and Operating Temperatures.^{1, 2}
- The lifter is not designed to be watertight. Do not use it in rain or other unsuitable conditions.

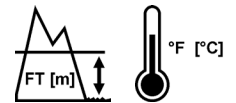

Moisture can result in reduced lifting capacity.

DISPOSAL OF THE LIFTER

After the Service Life of the vacuum lifter has ended (see “SPECIFICATIONS” on page 3), dispose of it in compliance with all local codes and applicable regulatory standards.

Note: Special disposal regulations may apply to the battery.

1..... Although lifter use may be possible at higher elevation, lifting capacity is reduced whenever the lifter is unable to attain vacuum in the green range on the vacuum gauge. Contact WPG for more information.

2..... Special provisions may allow the lifter to operate outside the specified temperature range. Contact WPG for more information.

BEFORE USING THE LIFTER

Determine whether the vacuum lifter is capable of each intended task (see “SPECIFICATIONS” on page 3 and “INTENDED USE” on page 12). Then complete the following preparations:

Taking Safety Precautions

- Be trained in all industry and regulatory standards for lifter operation in your region.
- Follow trade association guidelines about precautions needed for each load material.



Read all directions and safety rules before using lifter.



Always wear appropriate personal protective equipment.

Performing Inspections and Tests

- Follow the “INSPECTION SCHEDULE” on page 25 and “TESTING” on page 26.
- Service the air filter whenever the bowl contains liquid or other contaminants, or the element appears dirty (see “AIR FILTER MAINTENANCE” in *SERVICE MANUAL*).
- If the lifter has a low vacuum warning buzzer (fig. 1A), make sure it is clearly audible at the maximum distance between the operator and the lifter, despite any barriers or obstacles.^{1, 2}



Examine air filter regularly and service when needed.



Make sure warning buzzer can be heard over noise at operator position.

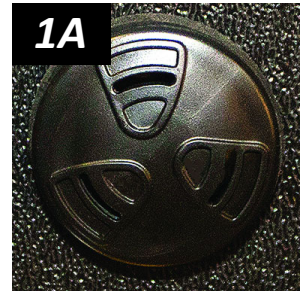

1..... Maximum alarm volume is 103 dBA at 2' [60 cm]. If CE Standards apply, consult EN 7731 to make sure the warning buzzer is compliant.

2..... The “Vacuum Test” on page 27 provides a convenient opportunity to check this.

Checking the Battery



Always check battery energy before every lift.

Use the battery gauge to determine whether the battery needs to be charged (see “BATTERY RECHARGE” on page 31).¹ Never use the lifter unless battery energy appears in the green range.

- While the valve handle is in the “attach” position (|← / power on), the battery gauge automatically shows battery energy.²
- While the valve handle is in the “release” position (|→| / power off), use the battery test button (circled) to check the battery energy.³



- 1..... If the pump is running or the battery charger is connected to an AC power source, the reading on the battery gauge will not be accurate.
- 2..... After the vacuum pump stops running, the battery gauge requires a few moments to stabilize before it shows an accurate energy level.
- 3..... If the lifter has not been used since the battery was charged, the battery gauge may falsely show a high energy level. This “surface charge” dissipates after the pump runs for about 1 minute, allowing the gauge to show accurate energy.

OPERATION

To ATTACH THE PADS TO A LOAD

Make sure the contact surfaces of the load and vacuum pads are clean (see “Pad Cleaning” on page 30).



Positioning the Lifter on the Load

- 1) Center the pad frame on the load (fig. 1A).¹



- 2) Make sure all vacuum pads will fit on the load and will be loaded evenly (fig. 2A).

Consult the Per-Pad Load Capacity.



- 3) Place the vacuum pads in contact with the load surface.



1..... The lifter is designed to handle the maximum load weight when the load's center of gravity is positioned within 2" [5 cm] of the lifter's rotation axis. Uncentered loads may rotate or tilt unexpectedly.

OPERATION

Sealing the Pads on the Load

Pull the valve handle outward *until it latches* (circled in fig. 1A) in the “attach” position (⇐).

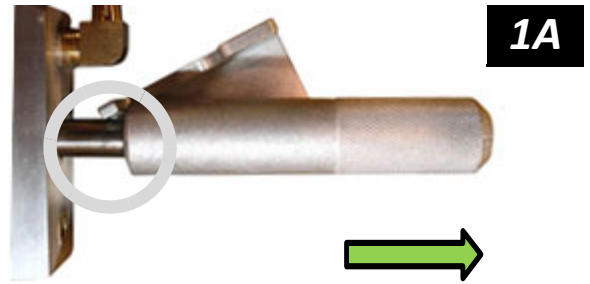

! *Keep valve handle in “attach” position throughout lift.*

The vacuum pump will turn on, the low vacuum warning light will remain lit and the low vacuum warning buzzer, if present, will sound until the vacuum pads seal. This is normal.

Press the lifter firmly against the load to help the pads begin to seal.¹

Reading the Vacuum Gauge

A vacuum gauge shows the current vacuum level in positive inches of Hg and negative kPa:

- **Green range** (≥ 16 " Hg [-54 kPa]): Vacuum level is sufficient to lift the maximum load weight (fig. 1B).
- **Red range** (< 16 " Hg [-54 kPa]): Vacuum level is *not* sufficient to lift the maximum load weight (fig. 1C).



If it takes more than 5 seconds for the vacuum level to reach 5" Hg [-17 kPa], press on any vacuum pad that has not yet sealed.

Once the pads have sealed, the lifter should be able to maintain sufficient vacuum for lifting, except when used above the maximum Operating Elevation.² If it does not:

- Make sure the vacuum switch is adjusted correctly (see *SERVICE MANUAL*).
- When necessary, perform the “Vacuum Test” on page 27.

1..... Although a vacuum pad may become distorted during shipping or storage, this condition should correct itself with continued use.

2..... If the lifter is used above the maximum Operating Elevation (see “SPECIFICATIONS” on page 3), it may not be able to maintain sufficient vacuum for lifting. Contact WPG for more information.

OPERATION

To Lift and Move the Load



Lift bar must be vertical to lift load.

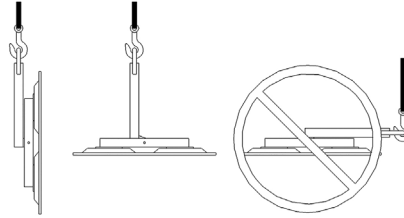

Interpreting the Warning Light and Optional Warning Buzzer



When the vacuum lifter is ready to lift the Maximum Load



Never lift load unless warning devices turn off, because this could result in load release and personal injury.

Capacity, the vacuum pump and the low vacuum warning light turn off temporarily, to conserve battery energy.

When air leaks into the vacuum system, the vacuum pump turns on and off (along with the warning light) as necessary to maintain sufficient vacuum for lifting.

Note: The low vacuum warning buzzer, if present, turns on and off together with the warning light.

Watching Vacuum Indicators

Watch the low vacuum warning light and the vacuum gauge (fig. 1A) throughout the entire lift.



Make sure vacuum indicators remain completely visible.

If the warning light turns on and the ***vacuum gauge shows a level less than 16" Hg [-54 kPa]:***

- 1) Keep everyone away from a suspended load until it can be safely lowered to a stable support.



Stay clear of any suspended load while indicators warn of low vacuum.

- 2) Stop using the lifter until the cause of the vacuum loss can be identified: Conduct the "Pad Inspection" on page 29 and perform the "Vacuum Test" on page 27.
- 3) Correct any faults before resuming normal operation of the lifter.



OPERATION

Controlling the Lifter and Load

When the lifter is ready, use the hoisting equipment to raise the lifter and load as needed.

Use the control handle (circled in fig. 1A) to keep the lifter and load in the required position.

Once there is enough clearance, you may move the load as required.



In Case of a Power Failure

A vacuum reserve tank helps maintain vacuum temporarily in the event of a battery failure or electrical system failure. Although the lifter is designed to support the load for at least 5 minutes without power, this depends on many factors, including the “LOAD CHARACTERISTICS” on page 12 and the condition of the vacuum pads (see “VACUUM PAD MAINTENANCE” on page 29).

If a power failure occurs, keep everyone away from a suspended load until it can be safely lowered to a stable support. Correct any faults before resuming normal operation of the lifter.



Stay clear of any suspended load during power failure.

OPERATION

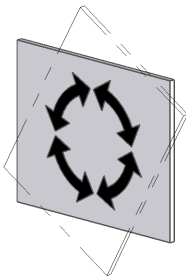
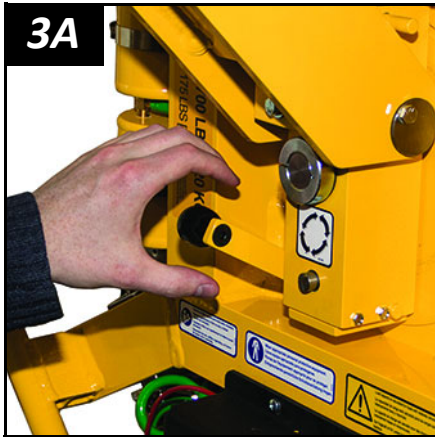

To ROTATE THE LOAD

- 1) Make sure the load has enough clearance to rotate without contacting anyone or anything.
- 2) Use the control handle (circled in fig. 2A) to keep the load under control at all times.
- 3) Pull the rotation release lever (fig. 3A) to disengage the rotation latch, and rotate the load as required.
- 4) To stop load motion, let go of the rotation release lever and guide the load to the next stop.



Make sure load is positioned correctly on lifter (as previously directed).



Never disengage rotation and tilt latches at the same time, because this could result in load damage or personal injury.



Unbalanced loads may rotate unexpectedly when rotation latch is disengaged.

Note: Whenever rotation is not required, keep the rotation latch engaged, to prevent load damage or personal injury.

OPERATION

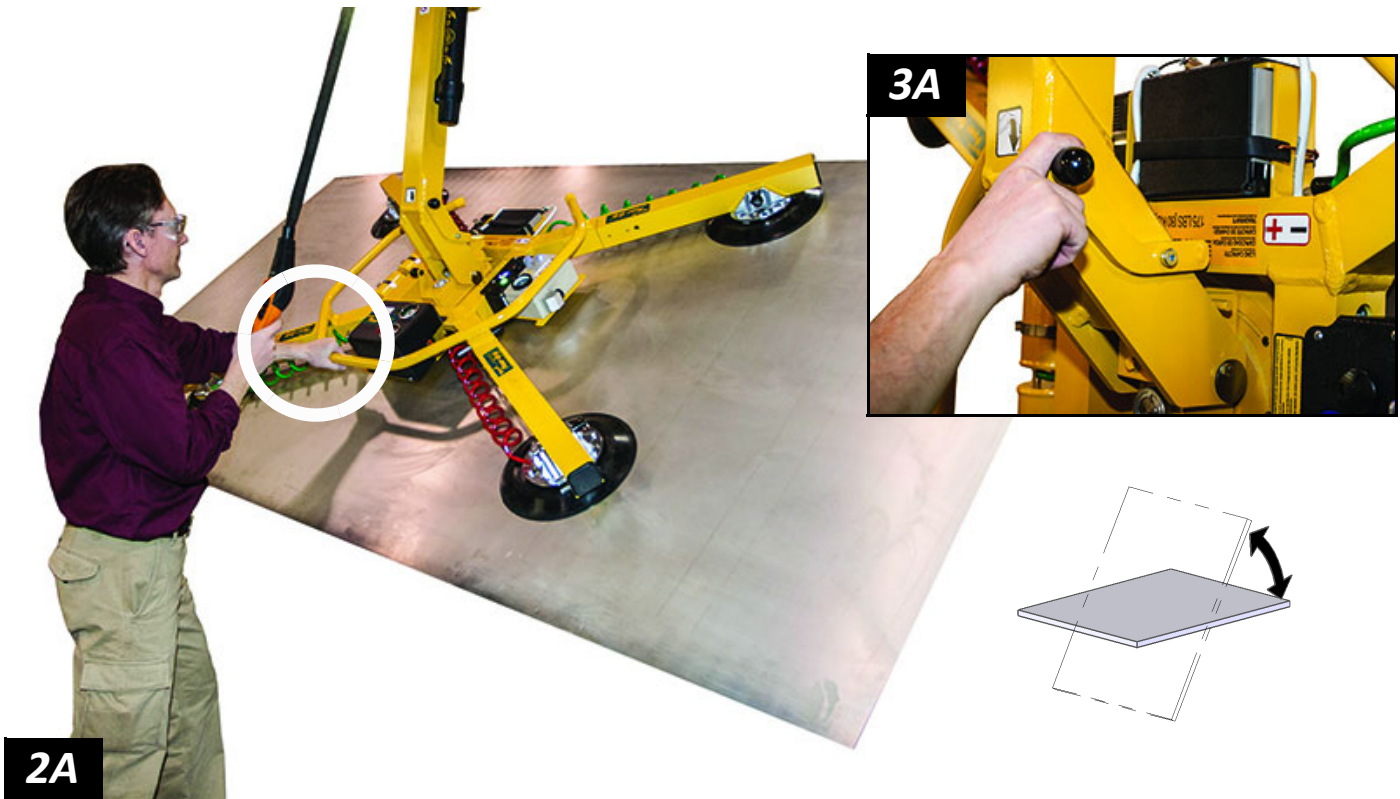

TO TILT THE LOAD

- 1) Make sure the load has enough clearance to tilt without contacting anyone or anything.
- 2) Use the control handle (circled in fig. 2A) to keep the load under control at all times.
- 3) If the pad frame is latched, pull the tilt release lever (fig. 3A) to disengage the tilt latch.

Note: The pad frame automatically latches when tilted to the vertical position.

- 4) Tilt the load as required.

Note: See "Load Characteristics" on page 12 about allowable load overhang.



Make sure load is positioned correctly on lifter (as previously directed).



Never disengage rotation and tilt latches at the same time, because this could result in load damage or personal injury.



Unbalanced loads may rotate unexpectedly when rotation latch is disengaged.

OPERATION

A load with overhang may force you to release the control handle as the load approaches the flat position. In this case, use hand cups (circled in fig. 1A) or other appropriate means to control the load.



OPERATION

TO RELEASE THE PADS FROM THE LIFT



Make sure load is at rest and fully supported before releasing vacuum pads.

- 1) Press the lever to release the latch and push the valve handle inward (fig. 1A) to the “release” position (|→|).

1A

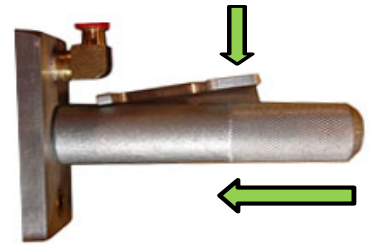

Do not move lifter until pads release completely, because such movement could result in load damage or personal injury.

- 2) Before you lift another load, perform the Every-Lift Inspection (see “INSPECTION SCHEDULE” on page 25).

AFTER USING THE LIFTER

- 1) Leave the valve handle in the “release” position (|→| / power off).
- 2) Charge the battery after each workday as needed (see “BATTERY RECHARGE” on page 31).¹
- 3) Use the hoisting equipment to lower the vacuum lifter gently onto a stable support. Then detach the hoisting hook from the lift point.

Caution: Do not set the lifter on surfaces that could soil or damage vacuum pads.

- 4) To transport the lifter, secure it in the original shipping container with the original restraints or equivalent.

Storing the Lifter

- 1) Use the pad covers supplied (fig. 1B) to keep the vacuum pads clean.

1B



1..... To maximize battery life, charge it promptly after each use.

OPERATION

!!-CE-!! To prevent the lifter from tipping over on relatively horizontal surfaces, place the vacuum pads facedown on a clean, smooth, flat surface. Then lower the lift bar and place a support under the lift point.

- 2) Charge the battery completely and repeat every 6 months (see “BATTERY RECHARGE” on page 31).

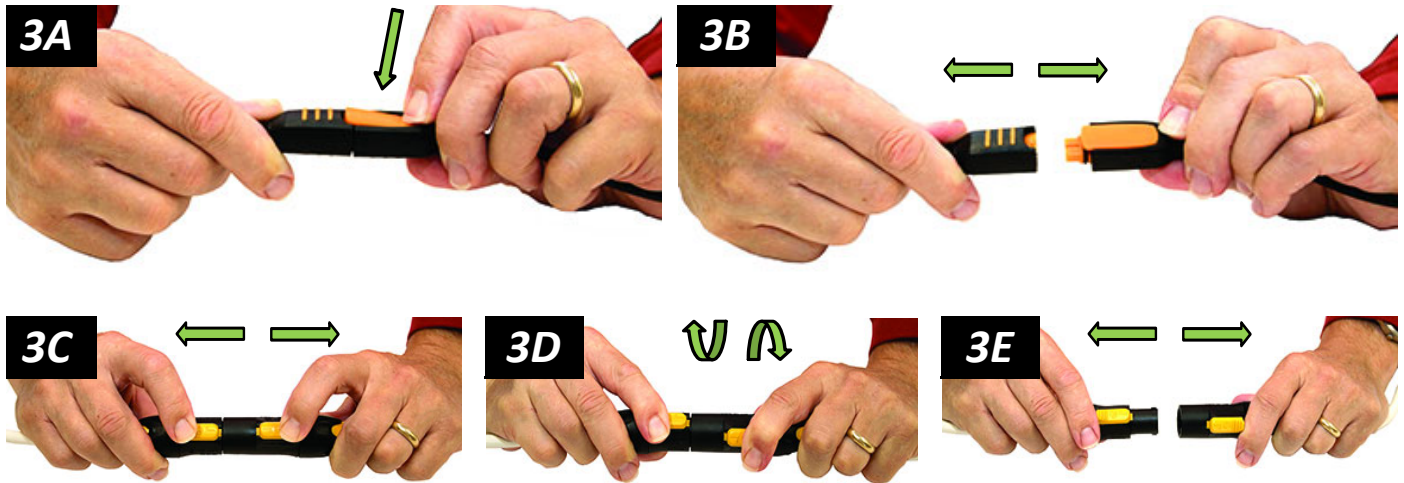

- 3) Disconnect the electrical connectors (figs. 3A-B and figs. 3C-E) to prevent battery discharge.
- 4) Store the lifter in a clean, dry location. Store the battery between 32° and 70° F [0-21° C]. Avoid storage above 100° F [38° C.]

INSPECTIONS AND TESTS

INSPECTION SCHEDULE

Perform inspections according to the following frequency schedule. If any fault is found, correct it and perform the next most frequent inspection before using the vacuum lifter.

Note: If a lifter is used less than 1 day in a 2-week period, perform the Periodic Inspection before using it.

Action	Every Lift	Frequent ¹ (every 20-40 hrs)	Periodic ² (every 250-400 hrs)
Examine <u>vacuum pads</u> for contaminants or damage (see “Pad Inspection” on page 29).	✓	✓	✓
Examine load surface for contaminants or debris.	✓	✓	✓
Examine controls and indicators for damage.	✓	✓	✓
Check <u>battery</u> for adequate charge (see “Checking the Battery” on page 15).	✓	✓	✓
Examine lifter’s structure for damage.		✓	✓
Examine vacuum system for damage (including <u>vacuum pads</u> , fittings and hoses).		✓	✓
Examine <u>air filter</u> for conditions requiring service (see “AIR FILTER MAINTENANCE” in <i>SERVICE MANUAL</i>).		✓	✓
Perform “Vacuum Test” on page 27.		✓	✓
Check for unusual vibrations or noises while operating lifter.		✓	✓
Examine entire lifter for evidence of: <ul style="list-style-type: none"> • looseness, excessive wear or excessive corrosion • deformation, cracks, dents to structural or functional components • cuts in vacuum pads or hoses • any other hazardous conditions 			✓
Inspect entire electrical system for damage, wear or contamination that could be hazardous, in compliance with all local codes and regulatory standards. <i>Caution: Use appropriate cleaning methods for each electrical part, as specified by codes and standards. Improper cleaning can damage parts.</i>			✓

1..... The Frequent Inspection is also required whenever the lifter has been out of service for 1 month or more.

2..... The Periodic Inspection is also required whenever the lifter has been out of service for 1 year or more. Keep a written record of all Periodic Inspections. If necessary, return the lifter to WPG or an authorized dealer for repair (see “LIMITED WARRANTY” on page 33).

TESTING

Perform the following test to determine whether or not a load surface is too porous or rough:

Lifter/Load Compatibility Test¹

- 1) Make sure the vacuum generating system is functioning correctly (see “Vacuum Test” on page 27).
- 2) Thoroughly clean the load surface and the vacuum pads (see “Pad Cleaning” on page 30).²
- 3) Place the load in the upright position on a stable support.³
- 4) Attach the vacuum pads to the load as previously directed.
- 5) After the vacuum pump stops running, disconnect the battery connector (see “AFTER USING THE LIFTER” on page 23).⁴
- 6) Raise the load a minimal distance, to make sure it is supported by the lifter.
- 7) Watch each vacuum gauge: ***Starting from a vacuum level of 16" Hg [-54 kPa], the lifter must maintain a vacuum level greater than 12" Hg [-41 kPa] for 5 minutes.***⁵ If not, lifting this load requires additional precautions (eg, a load sling). Contact WPG for more information.
- 8) Lower the load *after* 5 minutes or *before* the vacuum level diminishes to 12" Hg [-41 kPa].



Take precautions in case load should fall during test.

1..... The “Pad-to-Load Friction Coefficient” can affect the outcome of this test (see page 29).

2..... Contaminated loads can cause the vacuum pump to run frequently or continuously. Since excessive pumping quickly reduces battery energy, clean the load whenever possible.

3..... For Flat Lifters, place the load in the flat position.

4..... Move the valve handle to the “release” position (power off) *before* reconnecting the battery.

5..... Under CE requirements, the lifter must maintain a vacuum level ***greater than 8" [-27 kPa]***.

INSPECTIONS AND TESTS

Perform the following tests before placing the lifter in service *initially, following any repair, when directed in the “INSPECTION SCHEDULE”, or whenever necessary:*

Operational Tests

Test all features and functions of the lifter (see “OPERATING FEATURES” and “OPERATION”).

Vacuum Test

- 1) Clean the face of each vacuum pad (see “Pad Cleaning” on page 30).
- 2) Use a test load with weight equal to the Maximum Load Capacity, a clean, smooth, nonporous surface and other appropriate “LOAD CHARACTERISTICS” (see page 12).¹ 
- 3) Attach the lifter to the test load as previously directed. After the vacuum pump stops running, the vacuum level should appear in the green range on the vacuum gauge (if not, see “VACUUM SWITCH ADJUSTMENT” in *SERVICE MANUAL*).
- 4) Raise the load a minimal distance and disconnect the battery connector (see “AFTER USING THE LIFTER” on page 23).²

 **Take precautions in case load should fall during test.**
- 5) Watch the vacuum gauge: *The vacuum level should not decrease by more than 4" Hg [-14 kPa] in 5 minutes.*
- 6) Lower the load after 5 minutes or whenever a lifter fails the test, and release the load as previously directed.

 **Never use a lifter that has failed test.**
- 7) Qualified service personnel must correct any fault in the vacuum system before the lifter can be returned to service.³

1..... The load surface should have either a flat surface or no more curvature than the lifter is designed for, if any.

2..... Move the valve handle to the “release” position (power *off*) before reconnecting the battery.

3..... For more information, search for your lifter’s Model Number at www.WPG.com and select the “Troubleshooting” link on the product page.

INSPECTIONS AND TESTS

Rated Load Test¹

The following steps must be performed or supervised by a qualified person:²

- 1) Use a test load that weights 125% ($\pm 5\%$) of the Maximum Load Capacity and has the appropriate “LOAD CHARACTERISTICS” (see page 12).
- 2) Attach the vacuum pads to the load as previously directed.
- 3) Position the load to produce the greatest stress on the lifter consistent with “INTENDED USE” on page 12.
- 4) Raise the load a minimal distance and leave it suspended for 2 minutes.
- 5) Once the test is completed, lower the load for release as previously directed.
- 6) Inspect the lifter for any stress damage, and repair or replace components as necessary to successfully pass the test.
- 7) Prepare a written report of the test and keep it on file.



Take precautions in case load should fall during test.



Never use a lifter that has failed test.

1..... An equivalent simulation may also be used. Contact WPG for more information.

2..... A “qualified person” has successfully demonstrated the ability to solve problems relating to the subject matter and work, either by possessing a recognized degree in an applicable field or a certificate of professional standing, or by possessing extensive knowledge, training and experience.

MAINTENANCE

Notes: Refer to **SERVICE MANUAL #36110** when applicable. See final section for wiring diagrams.

VACUUM PAD MAINTENANCE

Pad-to-Load Friction Coefficient

The friction coefficient represents the lifter's ability to resist load slippage.¹ The Maximum Load Capacity is based on a friction coefficient of 1, as determined by testing of clean, new, standard rubber vacuum pads on clean, dry, regular glass. *If the lifter is used under any other conditions, a qualified person must first determine the effective lifting capacity.*²



Long-term exposure to heat, chemicals or UV light can reduce the friction coefficient of vacuum pads. Replace pads every 2 years or more often, when necessary.

Pad Inspection

Inspect each vacuum pad (fig. 1A) according to the “INSPECTION SCHEDULE” on page 25 and correct the following faults before using the lifter (see “REPLACEMENT PARTS”, when applicable):

- Contaminates on the face (1) or sealing edges (2).
- Filter screen (3) missing from face.
- Nicks, cuts or abrasions in sealing edges.

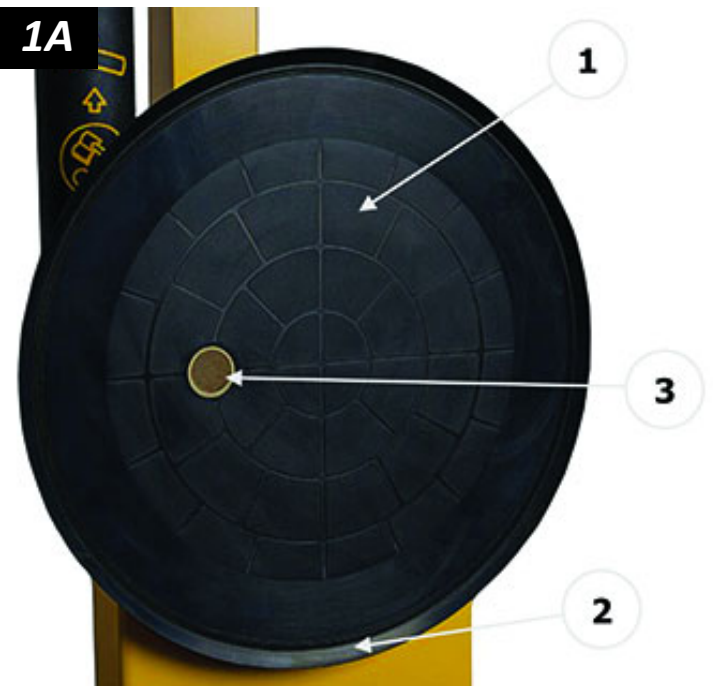

Replace any pad that has damaged sealing edges.

- Wear, stiffness or glaze.

1..... Not applicable to Flat Lifters.

2..... A “qualified person” has successfully demonstrated the ability to solve problems relating to the subject matter and work, either by possessing a recognized degree in an applicable field or a certificate of professional standing, or by possessing extensive knowledge, training and experience.

Pad Cleaning

- 1) Regularly clean the face of each vacuum pad (fig. 1A), using soapy water or other mild cleansers to remove oil, dust and other contaminants.



Never use harsh chemicals on vacuum pad.

Solvents, petroleum-based products (including kerosene, gasoline and diesel fuel) or other harsh chemicals can damage vacuum pads.



Never use rubber conditioners on vacuum pad.

Many rubber conditioners can leave a hazardous film on vacuum pads.

- 2) Prevent liquid from entering the vacuum system through the suction hole on the pad face.
- 3) Wipe the pad face clean, using a clean sponge or lint-free cloth to apply the cleanser.¹
- 4) Allow the pad to dry completely before using the lifter.



1..... A brush with bristles *that do not harm rubber* can help remove contaminants clinging to sealing edges. If these cleaning methods are not successful, contact WPG or an authorized dealer for assistance.

BATTERY RECHARGE

Charge the battery whenever the battery gauge shows reduced energy. *Caution: Make sure valve handle is in “release” position (|→| / power off).*

Identify the input voltage marked on the battery charger, and plug it in to an appropriate power source.¹



Make sure power source has ground fault circuit interrupter.

The power lamp (Φ) turns on when the charger is functioning. Consult the six-stage display to determine the charging status. The battery can be used after stage 3 and is fully charged at stage 5.

Normally, the battery should take no more than 8 hours to charge completely.² If not, check for the following faults:

- Power lamp (Φ) flashes: Charger is not connected to battery; reconnect charger (see “ASSEMBLY” on page 8).

- Error lamp (!) turns on immediately: Battery leads connected to wrong poles; reverse battery leads.

- Charging stops at stage 1 or 4, and error lamp (!) turns on: Battery is no longer functioning; replace battery (see “REPLACEMENT PARTS” on page 32).

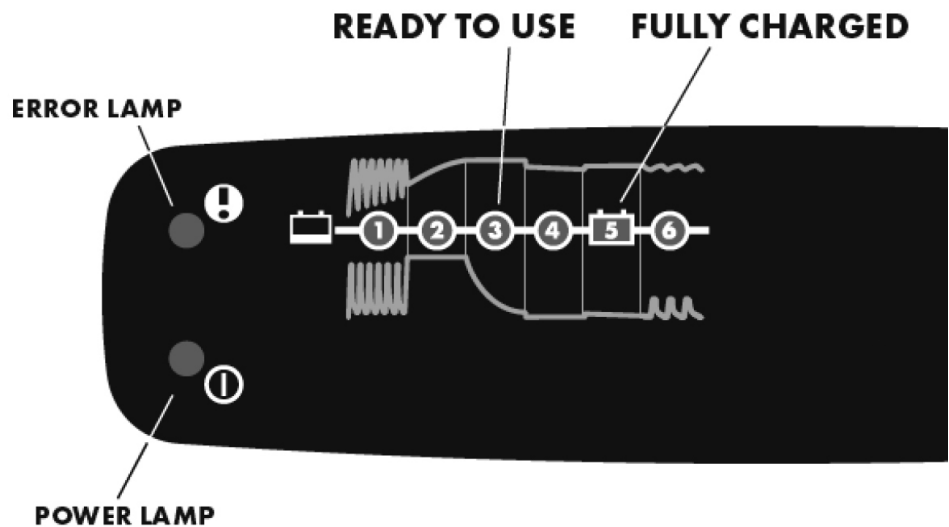

Before you return the lifter to service, recheck the battery as previously directed.

1..... Any external power supply must conform to all applicable local codes. This lifter is not intended for use while the charger is connected to AC power.

2..... The charger automatically reduces the charging rate when the battery is fully charged.

REPLACEMENT PARTS

Stock No.	Description	Qty.
65441	Vacuum Hose – 0.245" ID x 3/8" OD x 48" Length – Coiled	4
65440	Vacuum Hose – 0.245" ID x 3/8" OD	*
65014	Pad Spring – Wave Type (for HV11 pad)	4
65010	Pad Spring – Coil Type (for VPFS9 & G3370 pads)	4
64716	Battery Charger – 0.8 Amp – 240 V AC – Australian Type	1
64715	Battery Charger – 0.8 Amp – 240 V AC	1
64714	Battery Charger – 0.8 Amp – 100 / 120 V AC	1
64664	Battery – 12 V DC – 7 Amp-Hours	1
64283	Bulb – 13 V – Bayonet (for low vacuum warning light)	1
59086NC	Battery Connector – Twin Lead	1
59028	Movable Pad Mount – 2-1/2" Tubing Size	4
54390NC	Power Lead	1
53120	Pad Fitting – Elbow – 3/64" ID	4
53114	Hose Fitting – Coupler – 1/4" Barb	4
49646T	Vacuum Pad – Model G3370 / 11" [28 cm] Diameter – Lipped	4
49605T	Vacuum Pad – Model HV11 / 10" [25 cm] Diameter – Lipped	4
49506TA	Vacuum Pad – Model VPFS9 / 9" [23 cm] Diameter	4
49180	End Plug – 3" x 3" x 1/4" Tubing Size	1
49150	End Plug – 2-1/2" x 2-1/2" x 1/4" Tubing Size	4
36110	Service Manual – 12V DC, – 1 SFCM – Single Vacuum System – Manual Valve	1
29353	Pad Cover	4
15792	Tilt or Rotation Release Lever Knob	2
15632	Pad Filter Screen – Small (for VPFS9 pad)	4
15630	Pad Filter Screen – Large (for G3370 & HV11 pads)	4
13532	Cotterless Hitch Pin – 1/2" x 3-3/8"	8
10900	Shoulder Bolt – Socket Head – 5/16" x 1/2" x 1/4-20 Thread (for mounting pads)	24

*Length as required; vacuum hose is sold by the foot (approx. 30.5 cm).

See **SERVICE MANUAL #36110** for additional parts.

**SERVICE ONLY WITH IDENTICAL REPLACEMENT PARTS,
AVAILABLE AT WPG.COM OR THROUGH AN AUTHORIZED WPG DEALER**

LIMITED WARRANTY

Wood's Powr-Grip® (WPG) products are carefully constructed, thoroughly inspected at various stages of production, and individually tested. They are warranted to be free from defects in workmanship and materials for a period of one year from the date of purchase.

If a problem develops during the warranty period, follow the instructions below to obtain warranty service. If inspection shows that the problem is due to defective workmanship or materials, WPG will repair the product without charge.

Warranty does not apply when ...

- modifications have been made to the product after leaving the factory
- rubber portions have been cut or scratched during use;
- repairs are required due to abnormal wear and tear, and/or;
- the product has been damaged, misused or neglected.

If a problem is not covered under warranty, WPG will notify the customer of costs prior to repair. If the customer agrees to pay all repair costs and to receive the repaired product on a C.O.D. basis, WPG then will proceed with repairs.

TO OBTAIN REPAIRS OR WARRANTY SERVICE

For purchases in *North America*:

Contact the WPG Technical Service Department. When factory service is required, ship the complete product – prepaid – along with your name, address and phone number to the street address listed at the bottom of this page. WPG may be reached by phone or fax numbers listed below.

For purchases in *all other localities*:

Contact your dealer or the WPG Technical Service Department for assistance. WPG may be reached by phone or fax numbers listed below.

Wood's Powr-Grip Co., Inc.
908 West Main St.
Laurel, MT 59044 USA

406-628-8231 (phone)
800-548-7341 (phone)
406-628-8354 (fax)

WORKING TITLE: 705-W01 [D-W01]
 H:\Working\STD\705-DCP\UECN 30111

TYPE: **STANDARD**
 DIRECTORY: FILE SHEET

THIS DRAWING IS THE PROPERTY OF **WOOD'S POWR-GRIP CO., INC.**
 IT IS LOANED WITH THE UNDERSTANDING THAT NEITHER IT NOR ANY
 INFORMATION CONTAINED THEREIN WILL BE COPIED, PUBLISHED OR
 TRANSMITTED TO OTHERS WITHOUT EXPRESS WRITTEN PERMISSION.
 LAUREL, MONTANA U.S.A.

WIRE LEGEND: CONTROLLED BY WIRING SYMBOLS DRAWING EXCEPT AS NOTED AND BELOW.
 LINE STYLES AND WIDTHS FOR WIRE UNLESS NOTED OTHERWISE.
 --- 14AWG --- N/A --- 16AWG ---
 --- NOTE #1 ---

1 SCFM DC VACUUM PACKAGE
 N/A
 PIEZOELECTRIC BUZZER WIRING DIAGRAM
 D705-W01 [D-W01]

DATE: 11/14/2012
 BY: RAS
 EST. WEIGHT: N/A

SIZE: A
 SCALE: NONE
 REV: 4
 ECN NUMBER: 3011

DRAWN: L. RENNER
 DATE: 06/04/2003

CHECKED: *dl*
 DATE: 12-11-12

APPROVED: *Oliver*
 DATE: 12-12-12

NOTES:
 1) 16AWG OR 20AWG WIRE, BASED ON VACUUM PUMP USED.

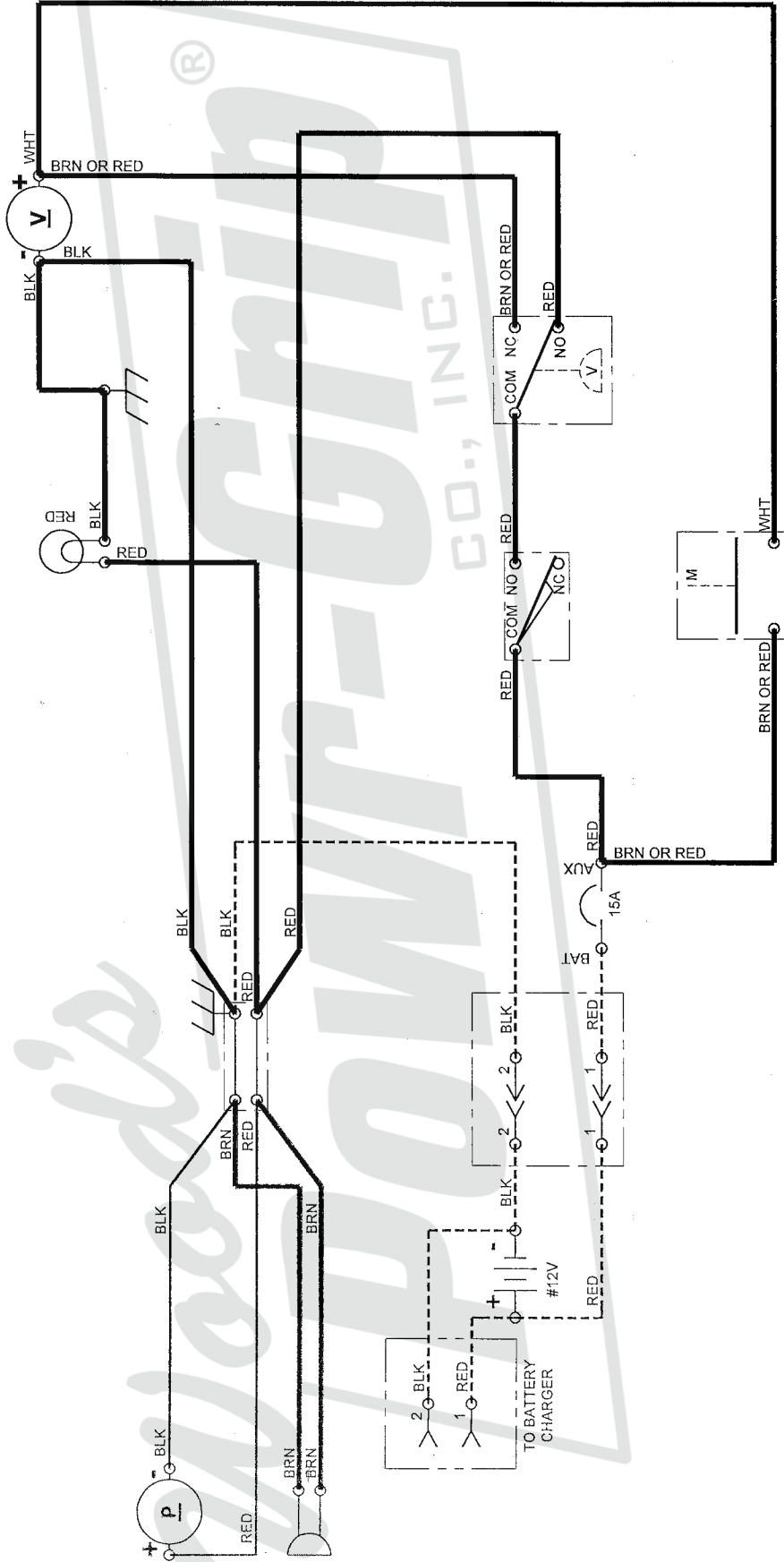

FILE DIRECTORY:
STANDARD
FILE (SHEET):

705-W06 [W06]

THIS DRAWING IS THE PROPERTY OF WOOD'S POWER-GRIP CO., INC. LAUREL, MONTANA U.S.A. IT IS LOANED WITH THE UNDERSTANDING THAT NEITHER IT NOR ANY INFORMATION CONTAINED THEREIN WILL BE COPIED, PUBLISHED OR TRANSMITTED TO OTHERS WITHOUT EXPRESS WRITTEN PERMISSION.



1 SCFM DC VACUUM PACKAGE

N/A

1 SCFM DC VACUUM SYSTEM WIRING SCHEMATIC, POWERCON D705-W06 [W06]

SIZE: A	SCALE: NONE	REVISION: 02.A	ECN NUMBER: 4170	ECN DATE: 11/02/2016	ECN BY: JAC	EST. WEIGHT: N/A
---------	-------------	----------------	------------------	----------------------	-------------	------------------

WIRE LEGEND: CONTROLLED BY WIRING SYMBOLS DRAWING EXCEPT AS NOTED AND BELOW.

LINE STYLES AND WIDTHS FOR WIRE UNLESS NOTED OTHERWISE.

PRODUCT MANAGER: KEITH B.

CHECKED: [Signature]

APPROVED: [Signature]

DATE: 10/27/2016

NOTE #1: 11-30-16

NOTE #2: 11-30-16



NOTES:
(1) 16 AWG OR 20 AWG WIRE, BASED ON VACUUM PUMP USED.

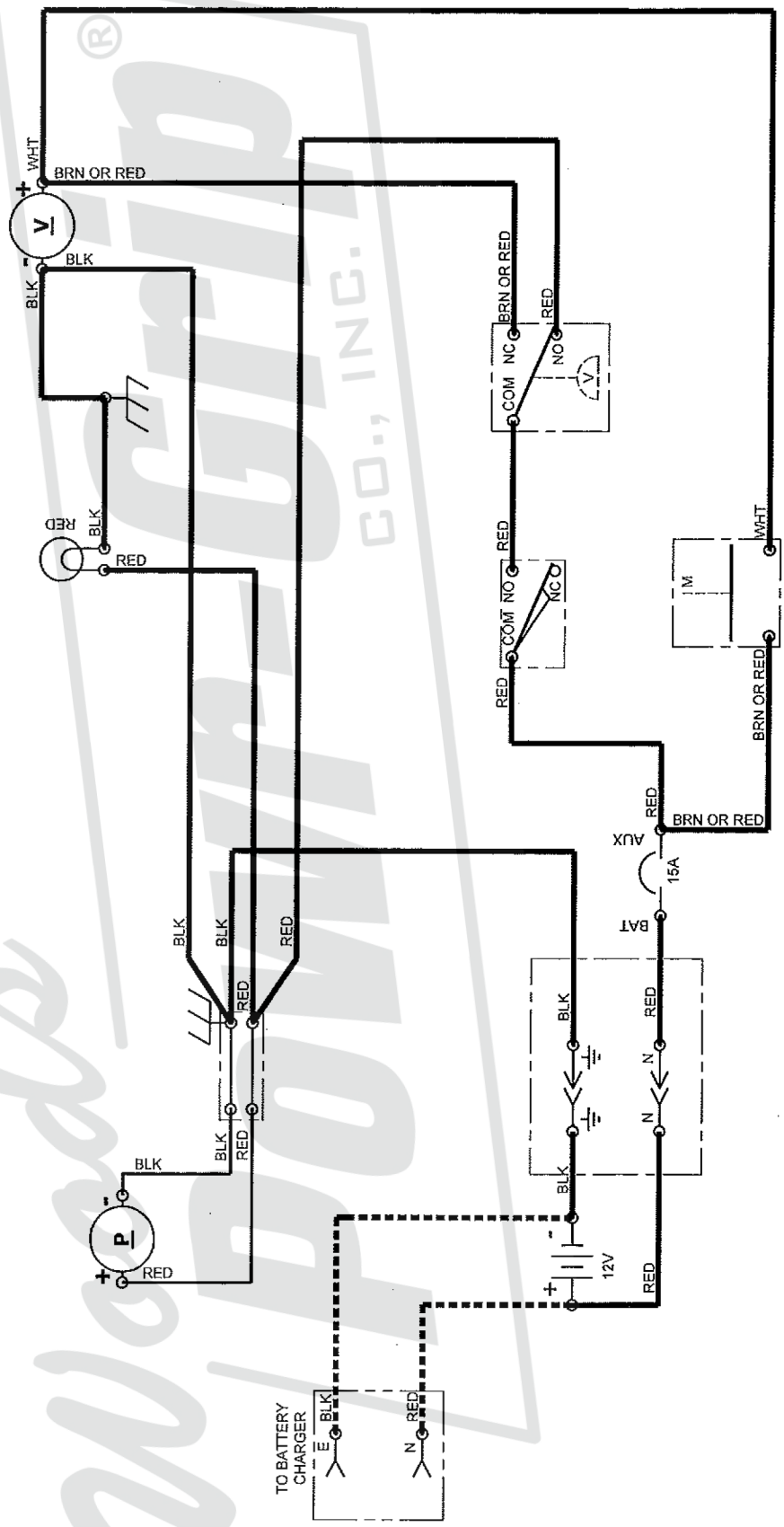
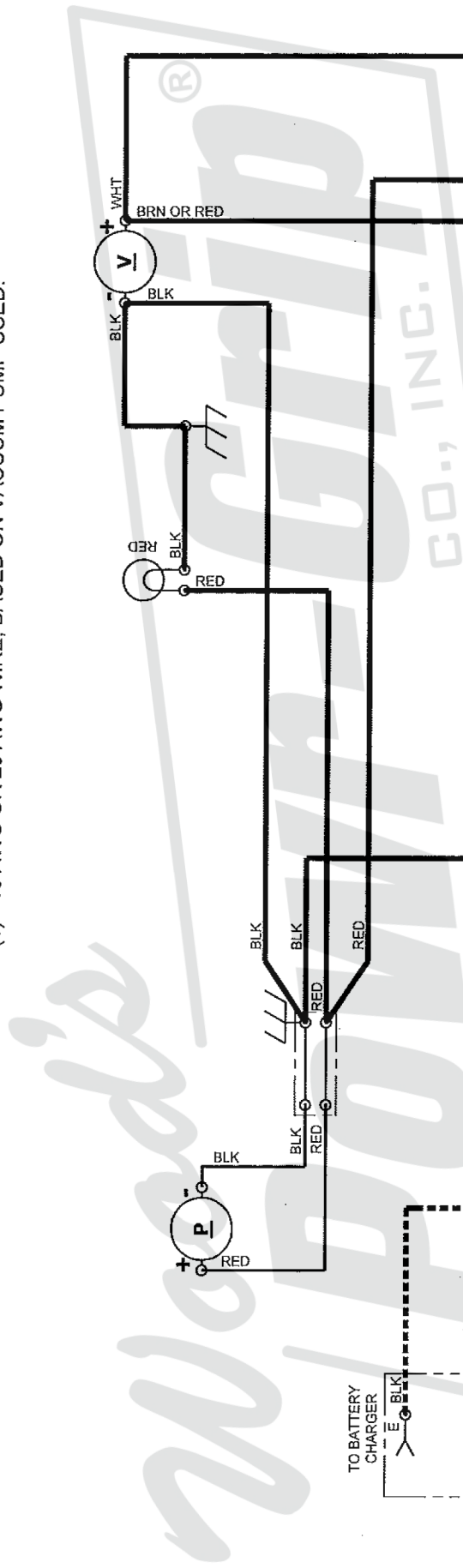

FILE DIRECTORY:
FILE (SHEET):

TYPE:
STANDARD

835-W01 [W01]

WIRE LEGEND: CONTROLLED BY
WIRING SYMBOLS DRAWING
EXCEPT AS NOTED AND BELOW.

LINE STYLES AND WIDTHS FOR
WIRE UNLESS NOTED OTHERWISE.

..... N/A 18AWG
..... N/A 16AWG

PRODUCT MANAGER:
SEAN E.

DATE:
08/15/2016

CHECKED:
SE

APPROVED:
SEAN

REVISION: ECN NUMBER: ECN DATE:

SCALE: NONE 02.A 4161 10/13/2016

SIZE: A

ECN BY: CCH

EST. WEIGHT: N/A



NOTES:
1) 16AWG OR 20AWG WIRE, BASED ON VACUUM
PUMP USED.

700LB MANUAL-ROTATOR/FILTER
N/A
SVS DC VACUUM PACKAGE WIRING SCHEMATIC
D835-W01 [W01]

TYPE:	STANDARD	FILE DIRECTORY:	FILE (SHEET):	835-W01 [W01]
WIRE LEGEND:	CONTROLLED BY WIRING SYMBOLS DRAWING EXCEPT AS NOTED AND BELOW.	LINE STYLES AND WIDTHS FOR WIRE UNLESS NOTED OTHERWISE. N/A 18AWG N/A 16AWG	PRODUCT MANAGER: SEAN E.
CHECKED:	<i>SE</i>	DATE:	08/15/2016	
APPROVED:	<i>SEAN</i>	REVISION:	ECN NUMBER:	ECN DATE:
	SCALE: NONE	02.A	4161	10/13/2016
	SIZE: A			ECN BY: CCH
				EST. WEIGHT: N/A

